

1970 BY AMP INCORPORATED. ALL RIGHTS RESERVED. AMP PRODUCTS COVERED BY PATENTS AND/OR PATENTS PENDING.

Unpublished copy not to be reproduced or distributed without written permission of AMP Incorporated

REVISIONS				
ZONE	LTR	DESCRIPTION	DATE	APPROVED
S		SUPERSEDED -3, -5, -6 WITH -4 / R-262A	6-18-87	MPH E/PT
T		REACTIVATE -3 ECN DF-0716 CT	8-88	Tom South

204873-2 1. AS SHOWN
 2. PLATED .000050 GOLD PER MIL-G-45204 OVER NICKEL PER QQ-N-290.
 204873-3 1. SAME AS -4 EXCEPT:
 MOUNTED ON MYLAR TAPE

204873-4 1. SAME AS -2 EXCEPT:
 2. COLOR CODED AS INDICATED.

SUPERSEDED BY -4 204873-5 1. SAME AS -2 EXCEPT:
 2. GRAPHITE COATED.

SUPERSEDED BY -4 204873-6 1. SAME AS -2 EXCEPT:
 2. COLOR CODE TO BE SINGLE BLACK BAND

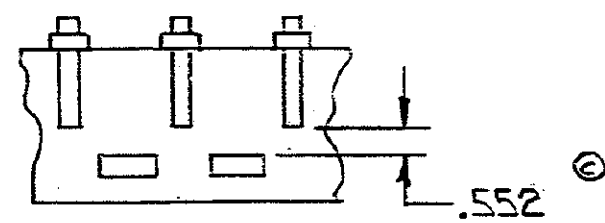
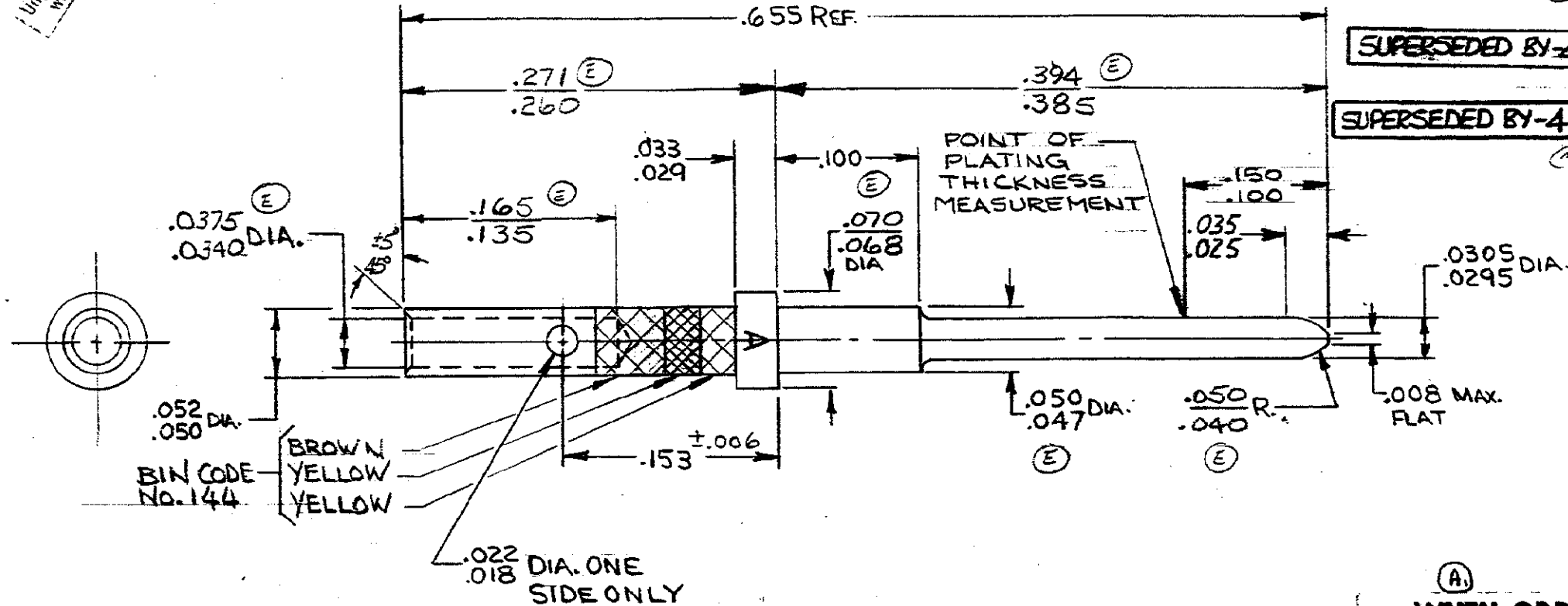

(A) WHEN ORDERING CONTACT ON TAPE, ORDER BY THE TAPE NUMBER PLUS THE PACKAGING CODE AS FOLLOWS:
 1. FOR USE WITH AMP TAPETRONIC, PNEUMATIC TOOL -
 A. 1000 PARTS TO A BOX ADD PACKAGING CODE 1MBOX
 2. FOR USE WITH 418 INDENT STRIPPER CRIMPER -
 A. 1000 PARTS TO A REEL ADD PACKAGING CODE 1MREEL
 B. 5000 PARTS TO A REEL ADD PACKAGING CODE 5MREEL

UNLESS OTHERWISE SPECIFIED DIMENSIONS ARE IN INCHES TOLERANCES ON: DECIMALS ± .005 ANGLES ± ++	CONTRACT NO.		AMP HARRISBURG, PENNSYLVANIA	
	DR. <i>P. Morningstar</i> 7-17-70			
MATERIAL LEADED COPPER	NAME		CONTACT, PIN # 22	
	CHK. <i>D. Miller</i> 8-26-70			
	APPROD. <i>R. S. 7-31-70</i> <i>Dick</i> 7-31-70	SIZE	CODE IDENT NO.	NUMBER
	DSGN APPD. <i>D. Kundle</i> 7/31/70	B	00779	204873
	OTHER APPD.	SCALE 10-1	SHEET 1 OF 1	